

PARÇA KODU PART CODE	PARÇA ADI PART NAME	s ÖLÇÜSÜ (KALINLIK) s MEASURE (THICKNESS)	Malzeme Material	Kaplama / Coating		
				SN	AG	Nİ
TŞ 2412 DP	ŞASE TERMİNAL Ø2.8 =DP=	-----	(CuZn30) Pirinç / Brass	-	-	-
TŞ 2412 RP	ŞASE TERMİNAL Ø2.8 =RP=	-----	(CuZn30) Pirinç / Brass	-	-	-
TŞ 2412 RPK	ŞASE TERMİNAL Ø2.8 =RPK=	-----	(CuZn30) Pirinç / Brass	+	-	-

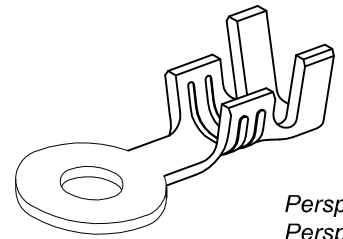

Perspektif
Perspective

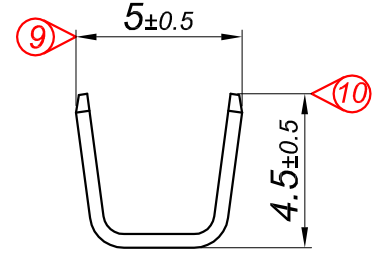
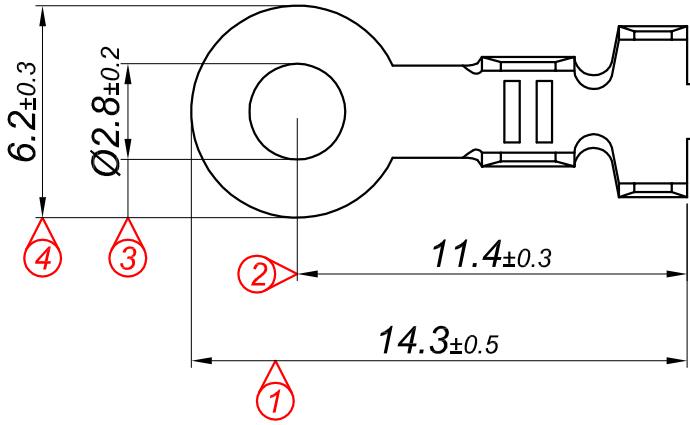
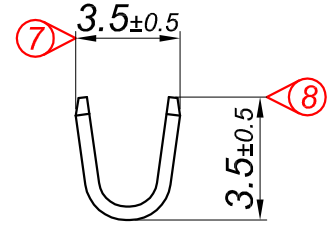
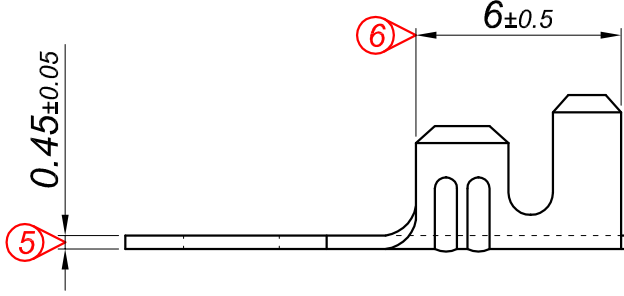
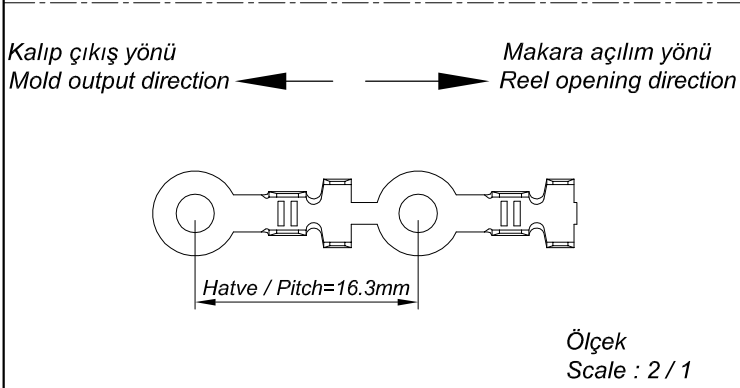

Kablo Kesiti

Wire Section : 0.50 - 1.50 mm²

Resim üzerinden ölçü almayınız
do not measure on drawing

Tarih / Date	19.07.2013	İmza /Signature	Ölçek /Scale			
Çizen / Desing	M.Yağcı		5 / 1			
Onay / Approval	S.Gölcük		No		Değişiklik / Revision	Tarih/Date



Parça Adı:
Part Name

ŞASE TERMİNAL Ø2.8

Parça Kodu:
Part Code

TŞ 2412